

HOOX-LOC Base Diagonal Corner Assembly

Step1: Slide bottom into hook grove on face frame.

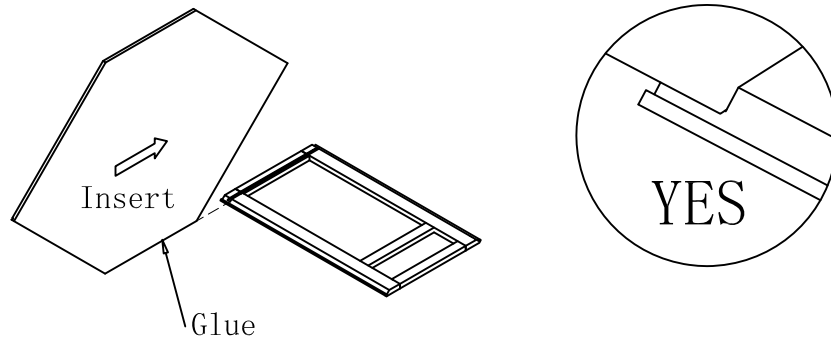

Step2: Slide side panels into hook grove on bottom.

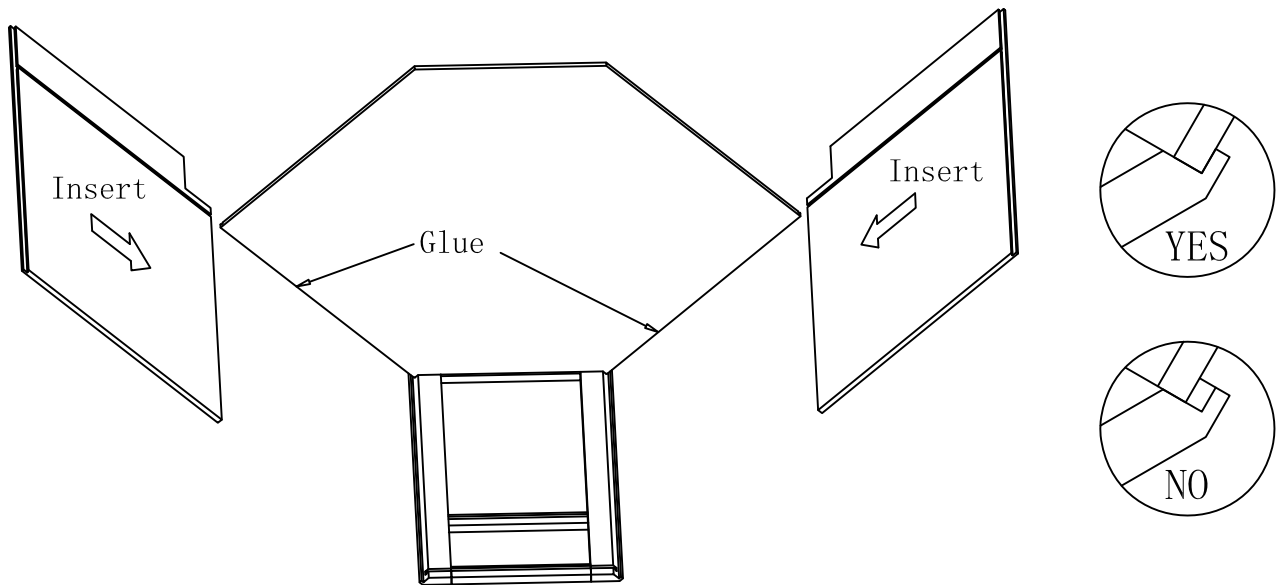

Step3: Install back panels screw into place.

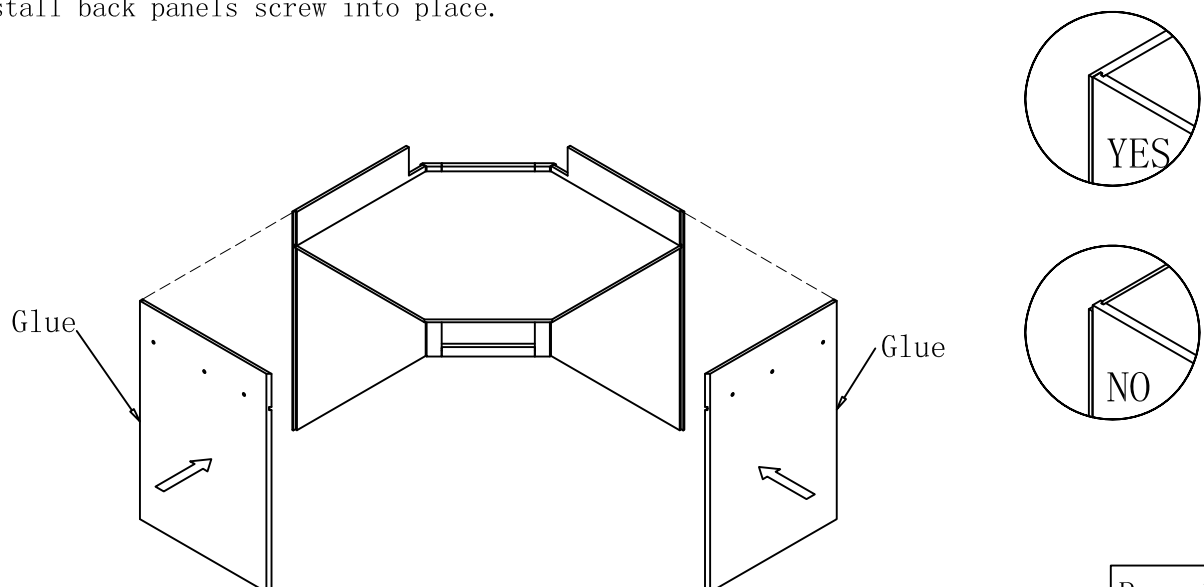

HOOX-LOC Base Diagonal Corner Assembly

Step4: Install corner back locking everything together screw into place .

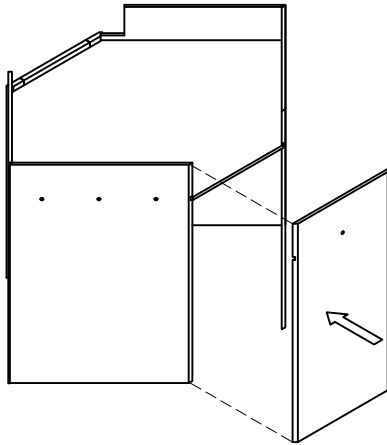
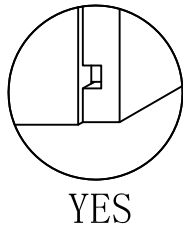

Step5: Install screws as show .

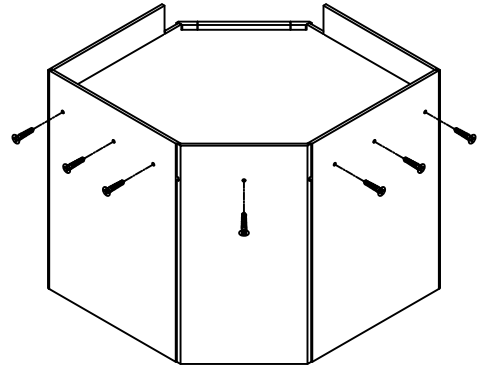

Step6: Install toe kick.

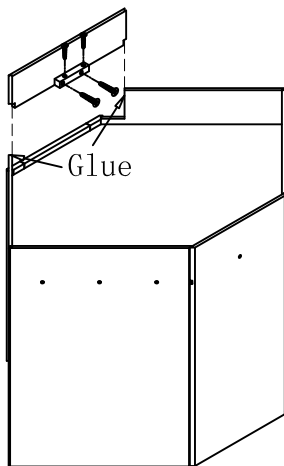
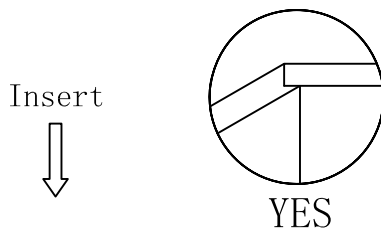

Step7:

- ⊙ Install angle wood blocks
- ⊙ Clean any excess glue.
- ⊙ Adjust doors.

